

Diagrams

When marking out from the plans, there is a simple way to maximize the use of the sheet of plywood. If you are not confident in marking out on your ply, templates can be cut from stiff cardboard and moved around for the best fit. It is then just a matter of tracing around the cardboard onto the plywood. The thickness of your saw cut needs to be taken into account.

Detail of nest box construction

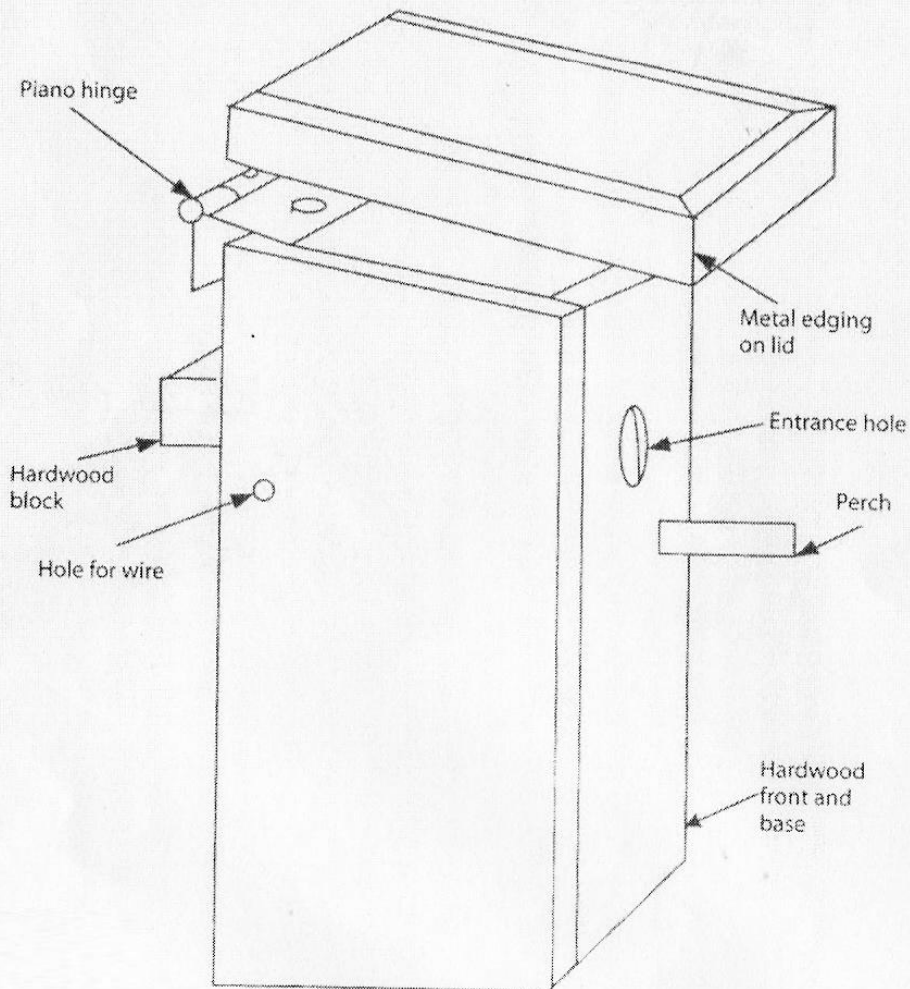

Ringtail/Brush-tail Possum

BOX

PLAN

These dimensions are for 19mm ply

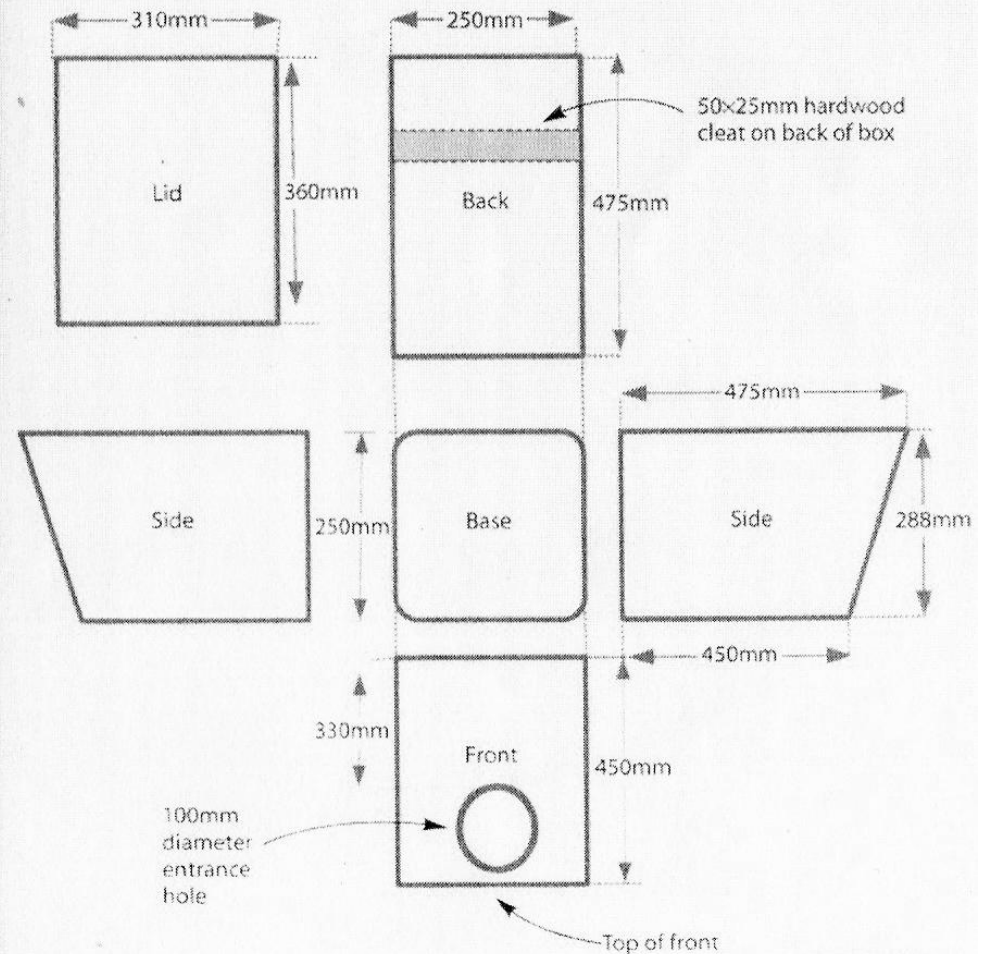

Figure 4.2

Not to scale